



PRIMEO® meter box

THE MULTI-PURPOSE METER BOX

The PRIMEO® box comprises components made from a fibreglass-reinforced synthetic material. It can be used as a **meter box** (underground in-line meter), enabling customers to be connected to the water distribution network.

PRIMEO® can be installed in green spaces and private gardens, thereby representing **the ideal solution for watering or irrigation equipment**.

The PRIMEO® meter box includes the following elements:

- Cover with sill (lockable or customisable on request) able to withstand 500 kg load
- Insulation fitted beneath cover (optional)
- Extension section (optional)
- Knockouts for inlets/outlets
- Bottom (optional)



> PRODUCT DESCRIPTION

Marking*

Identification on cover:
"Customer"/distribution service logo

Cover

Black/green cover

Insulation (optional)

Insulation beneath cover against freezing

Extension section

H = 150 mm (optional)

Chamber

Bottom (optional)

Equipped with fastening bosses (e.g. meter support)



Easy installation and handling:

- Weight: 5 kg
- Reduced impact on ground
- Knockouts for inlets/outlets

Applications:

- Connection to water distribution network
- Automatic watering system
- Hydrant

Resistance:

- 500 kg



Meter integration:

- Enables integration of **DN15 and 20** meters, with PE Ø 25 and PE Ø 32 connections

*Marking on cover: please contact us

**Extension section sold with fastening kit ref: 0974.009

> METER CONFIGURATION EXAMPLES



1 DN15
meter



2 DN15
meters

> DIMENSIONS

in mm

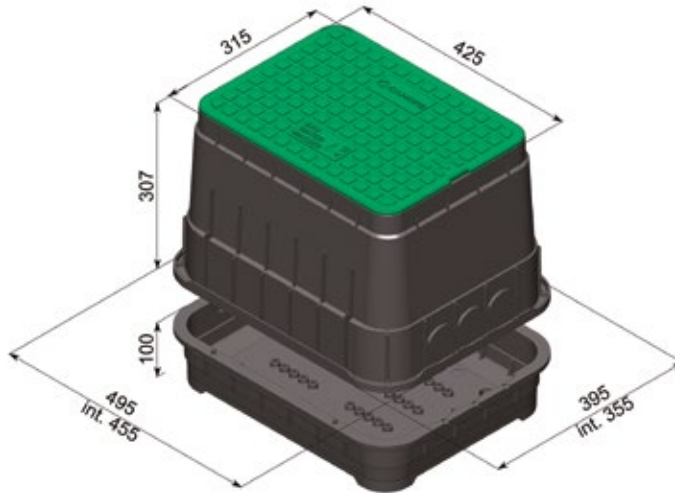

> REFERENCES

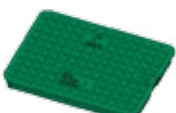
Cover	Insulation		Bottom	Reference	Packaging
	Without insulation	Insulated cover			
 Black		●		0294.150	72/pallet
	●			0294.151	
		●	●	0294.152	24/pallet
	●		●	0294.153	
		●	●	0258.000*	
 Green		●		0294.154	72/pallet
	●			0294.155	
		●	●	0294.156	24/pallet
	●		●	0294.157	
Extension section H = 150 mm	Sold with fastening kit			0974.009	-

*1 inlet/1 outlet drill holes (Ø 50 mm with sealing end-piece)