



# Connection and meter boxes



## Use

Boxes and pillars installed outside, on property boundary. Functions: cut-off, drainage, anti-pollution, metering.



## Description

Manufactured from fibreglass-reinforced polyester. Optimal resistance to impact and external hazards. Various types of insulation against freezing available depending on risk.

## Features

Chamber equipped with bosses for mounting rails. Pivoting door with 90° or 180° opening depending on version.

## > MININTER BOX



**Mininter box**  
Rectangular closure - Brass  
Ref. 0258.309



**Fully insulated Mininter box**  
Ref. 0258.313

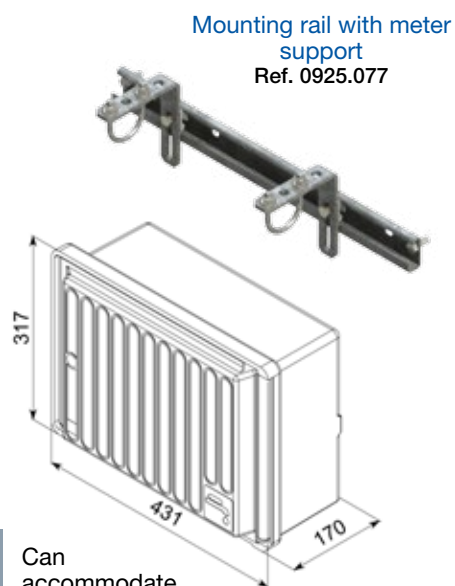
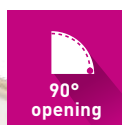

**Mounting rail with meter support**  
Ref. 0925.077

Dimensions	Insulation	Width (mm)	Height (mm)	Depth (mm)	Weight (kg)
External	•	431	317	191	4
	None	380	280	170	
Internal	Insulated door	380	280	130	
	Fully insulated	305	200	105	



Can accommodate 1 DN15 meter

Description	Reference	Packaging
Box without meter support	0258.309	49/pallet
Box with horizontal meter support	0258.310	
Box with insulated door without meter support	0258.311	
Box with insulated door with horizontal meter support	0258.312	
Fully insulated box without meter support	0258.313	
Fully insulated box with horizontal meter support	0258.314	
Accessories		
Non-insulated door	0925.685	
Insulated door	0925.686	
Mounting rail with meter support	0925.077	
Bottom door pin + spring	0925.047	
Tropical zones		
Standard water box for base (open bottom + 2 ø 50 mm on sides)	0258.129	
Base (not insulated)	0258.336	

> MINIMIXT BOX



Minimixt box  
Rectangular closure - Brass  
Ref. 0258.231



Fully insulated Minimixt box  
(shown without rail)

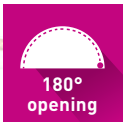

Mounting rail with meter support  
Horizontal mount, convertible to vertical  
Ref. 0258.765

Description	Reference	Pack.
Box without meter support	0258.228	45/ pallet
Box with vertical meter support	0258.233	
Box with insulated door without meter support	0258.229	
Box with insulated door with vertical meter support	0258.232	
Fully insulated box without meter support	0258.227	
Fully insulated box with h. + v. meter support	0258.231	

Accessories		
Non-insulated door	0925.764	
Insulated door	0925.749	
Mounting rail with h. + v. meter support	0925.765	
Top door pin accessory	0925.627	
Bottom door pin accessory	0925.628	

Dimensions	Insulation (mm)	Width (mm)	Height (mm)	Depth (mm)	Weight (kg)
External	•	350	485	197	6
Internal	Fully insulated	230	375	90	



Can accommodate  
1 DN15  
meter

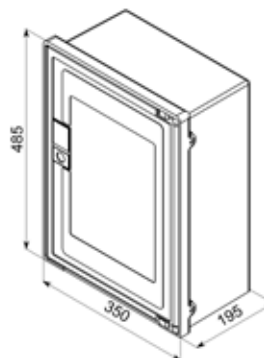

> PANINTER BOX



Paninter box  
Rectangular closure - Brass  
Ref. 0258.303



Fully insulated Paninter box  
(shown without rail)

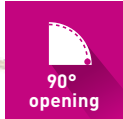

Can accommodate  
2 DN15  
or 1 DN20 meters



Mounting rail with meter support  
Ref. 0925.073

Dimensions	Insulation	Width (mm)	Height (mm)	Depth (mm)	Weight (kg)
External	•	535	516	230	7
	None	490	425	220	
Internal	Insulated door	490	425	170	
	Fully insulated	400	325	110	

Description	Reference	Packaging
Box without meter support	0258.303	21/pallet
Box with horizontal meter support	0258.304	
Box with insulated door without meter support	0258.305	
Box with insulated door with horizontal meter support	0258.306	
Fully insulated box without meter support	0258.307	
Fully insulated box with horizontal meter support	0258.308	
Base	0541.026	16/pallet
Bottom door pin + spring	0925.047	

Accessories		
Non-insulated door	0925.683	
Insulated door	0925.684	
Mounting rail with meter support	0925.073	

