

ANILLA



FIGURA 1

FIGURA 2

REFERENCIA PLASTIFICADO	DESIGNACION	1	2	ANILLA	L (mm)	B (mm)	C (mm)	FIGURA	REFERENCIAS CON T (*) TACO
0.563.011	ABC 70	4.018.010	5.111.718	SI	70	37	32	1	0.956.000 (4.018.035)
0.563.012	ABC 90	4.018.010	5.111.718	SI	90	45	32	1	0.956.000 (4.018.035)
0.563.012-I	ABC 90-I	4.250.242	4.018.028	SI	90	45	32	1	0.956.000 (4.018.035)
0.563.013	ABC 110	4.018.010	5.111.718	SI	110	55	32	1	0.956.000 (4.018.035)
0.563.013-I	ABC 110-I	-	-	SI	110	55	32	1	0.956.000 (4.018.035)
0.563.021	ABC-A	4.018.008	4.040.647	NO	110	38	62	2	
0.563.014	ABC 130	4.018.010	5.111.718	SI	130	60	32	1	0.956.004 (4.049.315)
0.563.015	ABC 150	4.018.010	4.018.025	SI	155	75	32	1	0.956.004 (4.049.315)
0.563.011-5	ABC 70-5	4.047.245	5.111.718	SI	74	37	50	1	0.956.004 (4.049.315)
0.563.012-5	ABC 90-5	4.047.245	5.111.718	SI	90	45	50	1	0.956.004 (4.049.315)
0.563.013-5	ABC 110-5	4.047.245	5.111.718	SI	110	55	32	1	0.956.000 (4.018.035)
0.563.014-5	ABC 130-5	4.047.245	5.111.718	SI	130	60	50	1	0.956.004 (4.049.315)
0.563.015-5	ABC 150-5	4.047.245	4.018.025	SI	155	75	50	1	0.956.004 (4.049.315)
0.563.020-5	ABC 200-5	4.047.245	4.049.305	SI	200	100	50	1	0.956.004 (4.049.315)
0.573.015	ABC 27-T	4.018.010	4.040.648	NO	125	40	32	2	0.956.000 (4.018.035)

(*) SI LAS REFERENCIAS Y DESIGNACIONES LLEVAN T AL FINAL, INCLUYEN EL TACO QUE SE INDICA EN LA TABLA

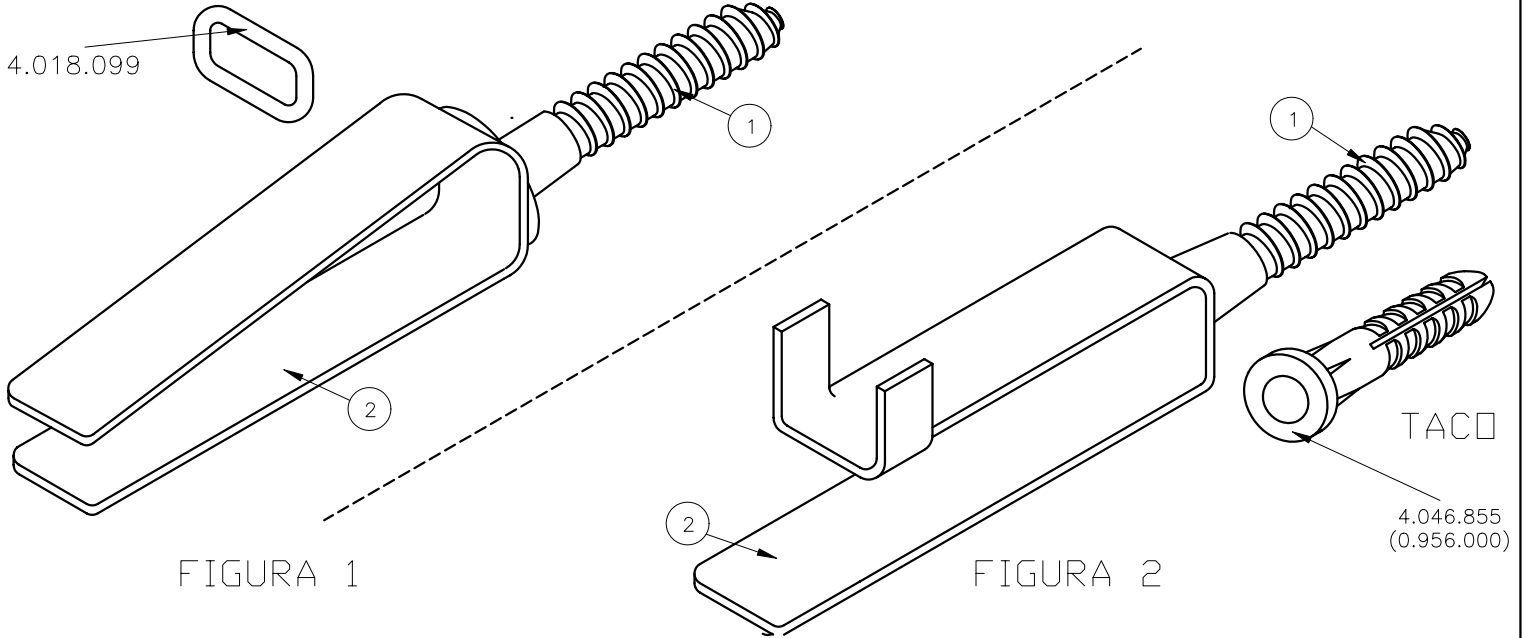
5					6				
3					4				
1					2				
N°	FECHA	POR	V.B	REVISION	N°	FECHA	POR	V.B	REVISION

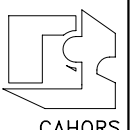

CAHORS

	PROYECT. MMM	MATERIAL:	ACABADO:
	ESCALA		
FECHA	CONTROL.	ABC	N° PM49882
99.08.18			N°R: 00
			N° PAGINA 26