

ANTI ESCALO ANT-HV 28x31  
Ref: 0740000

FICHA Nº

4920

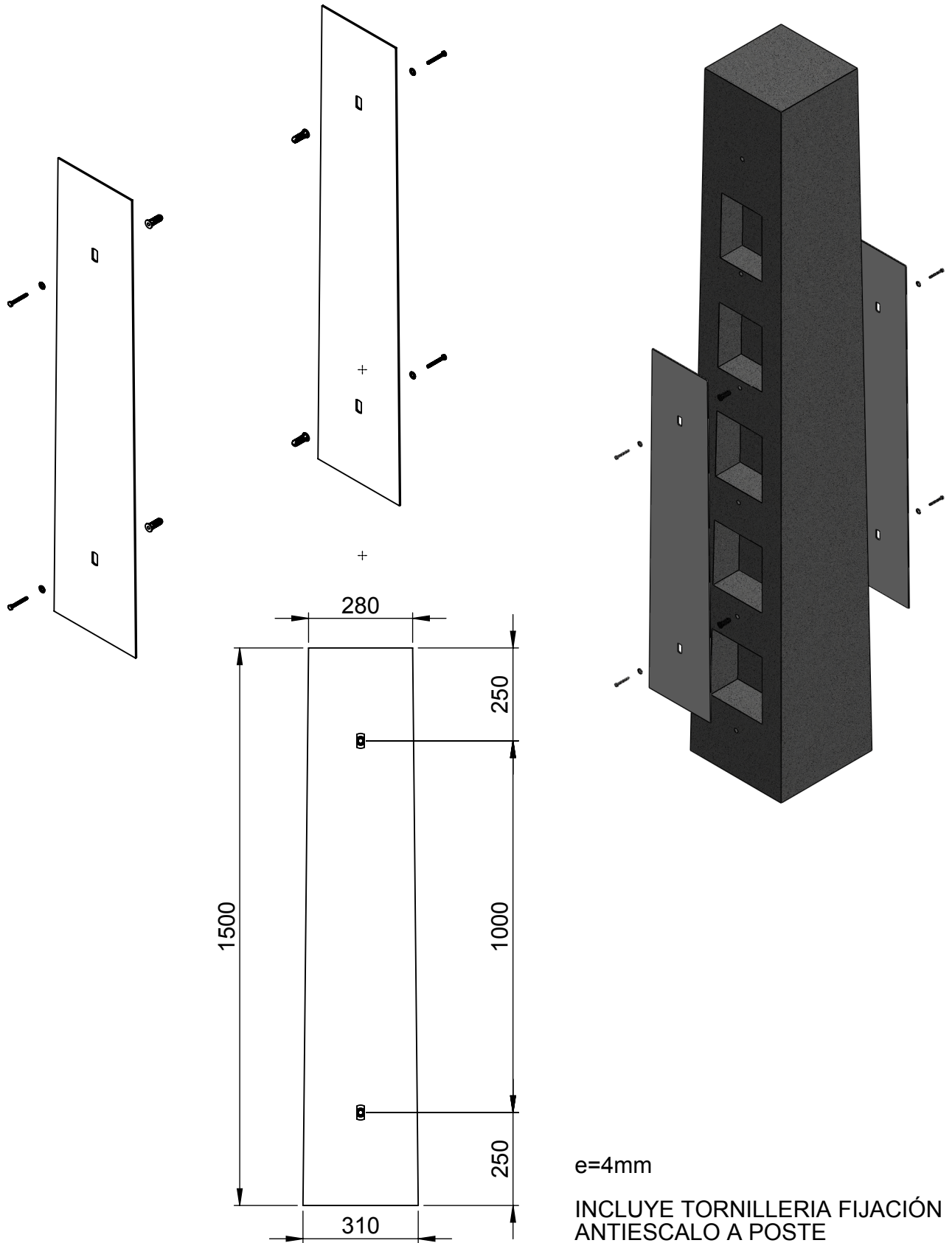

DIBUJADO

MCP

HOJA Nº

1/1

CAHORS ESPAÑOLA S.A

Apdo 70 Figueres (Girona) Ctra Vilamalla a Figueres km1

 CAHORS

FECHA: 22.04.2013